



# Minimalist, contemporary design. Factory glazed modules form continuous rooflights of unlimited length with large glazed areas and minimal framework.

Highly energy efficient, em.glaze linked glass-to-edge design offers uninterrupted views and stunning, modern aesthetics.

Exceptional performance perfectly blended with contemporary styling; em.glaze linked provides exceptional flexibility when designing a continuous rooflight.

em.glaze linked units feature a secure, welded frame with self-supporting joints, in popular anthracite grey colourway. Units can also be wall abutted.

em.glaze modules also feature a 'true' thermal break in the frame design, providing excellent sound insulation and thermal properties.

Safety is paramount when dealing with glass rooflights – em.glaze linked glass is CWCT tested to Class 2, as standard. Available with bespoke options including custom RAL powder-coating and heat strengthened laminate glazing.

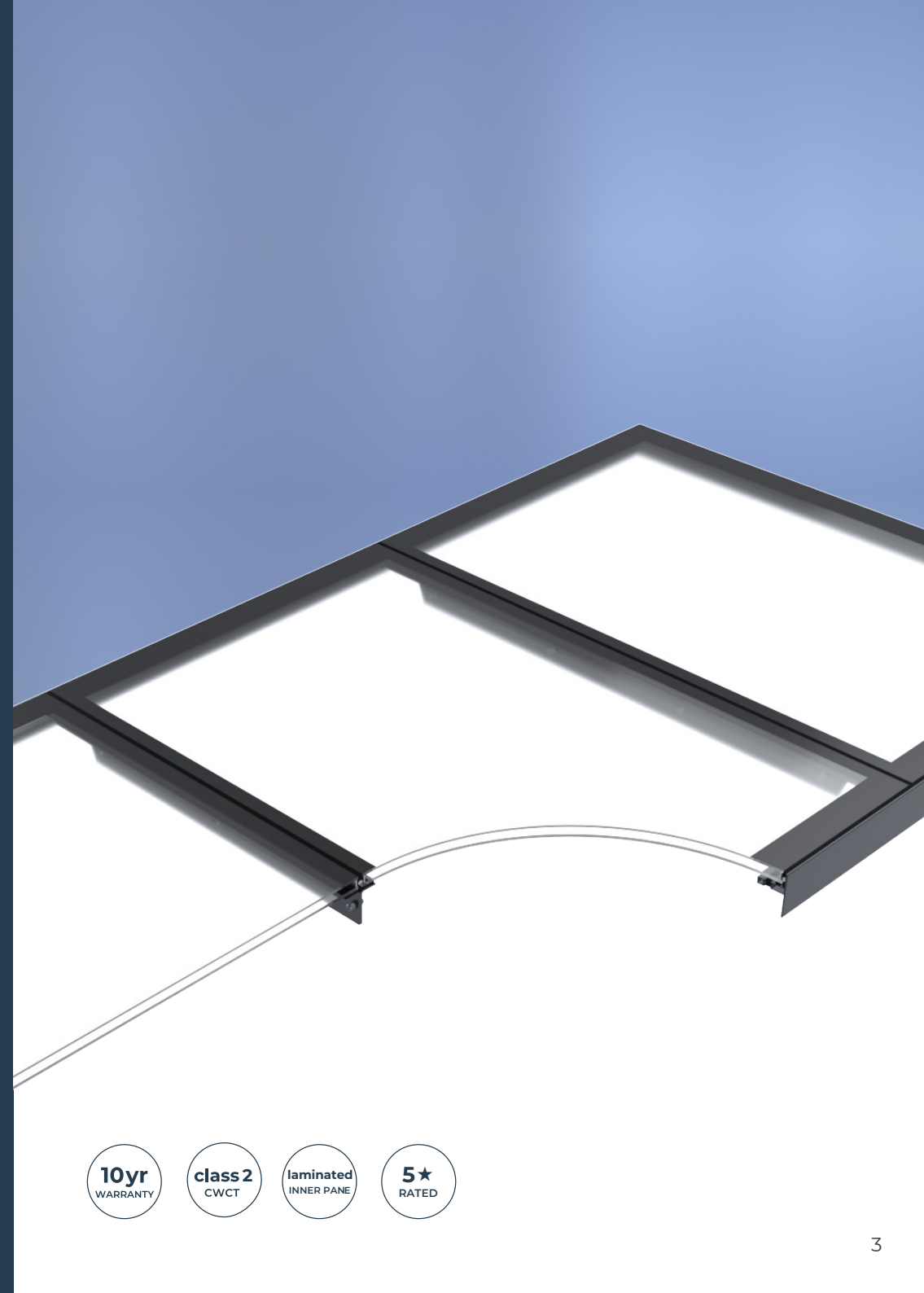

# Key Features & Benefits

- **Modular system** allows multiple glazed sections to be linked together with no external capping
- Non-fragility **CWCT Class 2** \*
- Secure, welded **thermally broken glazing frame** with self-supporting joints
- Can be **wall abutted**
- **Install pitch recommended 5 - 15°**; steeper incline generally no issue but consult Whitesales technical for further details
- Aluminium frame powder coated to **any RAL colour**
- Available in **bespoke** sizes and glass specifications
- Available as a **supply only** product

\* Refers to standard spec/size – dependent on glass specification required.





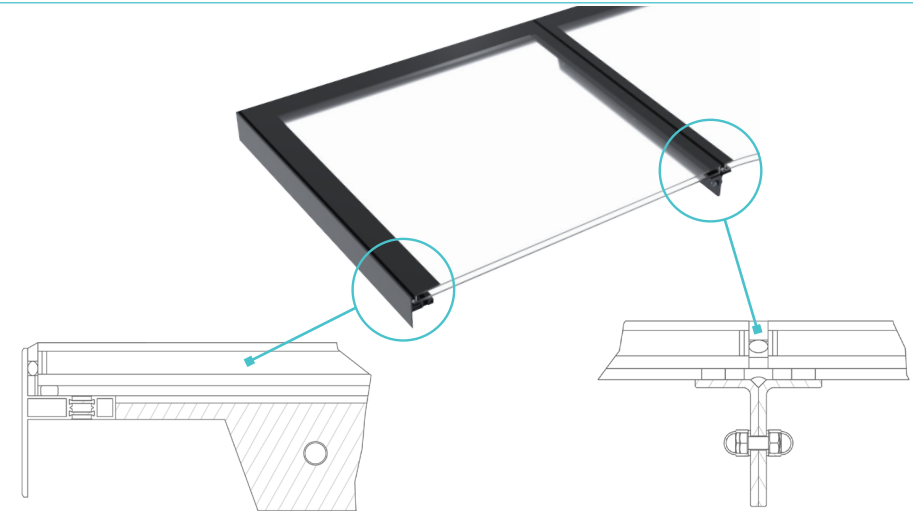

# Design Features



Frame	Aluminium
Gas	Argon
Warm spacer	✓
Toughened outer pane	✓
Laminated inner pane	✓
Thermal break + box section	✓
External frame colour	RAL 7016 anthracite grey or any standard RAL colour
Ud-value *	From 1.23 W/m <sup>2</sup> K (dependent on size)
Non-fragility	CWCT TN66/67 Class 2 on pane sizes up to 1m x 1.8m with 8.8mm inner or 1m x 3m with 11.5mm inner.
Water tightness BS EN 12155:2000 (for testing) BS EN 12154:2000 (for classification)	Class 7A at 300 Pa
Air permability BS EN 12153:2000 (for testing) BS EN 12152:2002 (for classification)	Class 2 300 Pa
Wind loading BS EN 12179:2000 (for testing) BS EN 13116:2001 (for classification)	Class A4

\* complete glass unit tested vertically

# Sizes & Glass Specification

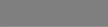
Key	
	2 section
	3 section
	4 section
	5 section
	6 section

Key	Glass Structure
*	6T / 16arg / 4 + 4 laminate
**	6T / 16arg / 5 + 5 laminate with 1,52 PVB
***	8T / 14arg / 5 + 5 laminate with 1,52 PVB
HSL	Optional Extra Cost: Option for inner 11.5mm pane to be Heat Strengthened Laminate



		Unit Width (mm)							
		2000	2250	2500	2750	3000	3250	3500	3750
Unit Downslope (mm)	800				*	*	*	*	*
	1000			*	*	*	*	*	*
	1200			*	*	*	*	*	*
	1400		*	*	*	*	*	*	*
	1600		*	*	*	*	*	*	*
	1800	*	*	*	*	*	*	*	*
	2000	** / HSL	** / HSL	** / HSL	** / HSL	** / HSL	** / HSL	** / HSL	** / HSL
	2200	*** / HSL	*** / HSL	*** / HSL	*** / HSL	*** / HSL	*** / HSL	*** / HSL	*** / HSL
	2400	*** / HSL	*** / HSL	*** / HSL	*** / HSL	*** / HSL	*** / HSL	*** / HSL	*** / HSL
	2600	*** / HSL	*** / HSL	*** / HSL	*** / HSL	*** / HSL	*** / HSL	*** / HSL	*** / HSL
2800	*** / HSL	*** / HSL	*** / HSL	*** / HSL	*** / HSL	*** / HSL	*** / HSL	*** / HSL	
3000	*** / HSL	*** / HSL	*** / HSL	*** / HSL	*** / HSL	*** / HSL	*** / HSL	*** / HSL	

		Unit Width (mm)								
		4000	4250	4500	4750	5000	5250	5500	5750	6000
Unit Downslope (mm)	800	*	*	*	*	*	*	*	*	*
	1000	*	*	*	*	*	*	*	*	*
	1200	*	*	*	*	*	*	*	*	*
	1400	*	*	*	*	*	*	*	*	*
	1600	*	*	*	*	*	*	*	*	*
	1800	*	*	*	*	*	*	*	*	*
	2000	** / HSL	** / HSL	** / HSL	** / HSL	** / HSL	** / HSL	** / HSL	** / HSL	** / HSL
	2200	*** / HSL	*** / HSL	*** / HSL	*** / HSL	*** / HSL	*** / HSL	*** / HSL	*** / HSL	*** / HSL
	2400	*** / HSL	*** / HSL	*** / HSL	*** / HSL	*** / HSL	*** / HSL	*** / HSL	*** / HSL	*** / HSL
	2600	*** / HSL	*** / HSL	*** / HSL	*** / HSL	*** / HSL	*** / HSL	*** / HSL	*** / HSL	*** / HSL
2800	*** / HSL	*** / HSL	*** / HSL	*** / HSL	*** / HSL	*** / HSL	*** / HSL	*** / HSL	*** / HSL	
3000	*** / HSL	*** / HSL	*** / HSL	*** / HSL	*** / HSL	*** / HSL	*** / HSL	*** / HSL	*** / HSL	

2022

# experience.brighter

Delivering on our promises, that is our focus – and it is what makes us the no.1 choice for professionals.



whitesales

Europa House, Alfold Road,  
Cranleigh, GU6 8NQ  
Tel: 01483 917580 | Fax: 01483 271771  
sales@whitesales.co.uk | whitesales.co.uk

Opening Times: 07:30 –16:30

